

ASSA ABLOY Glass Solutions

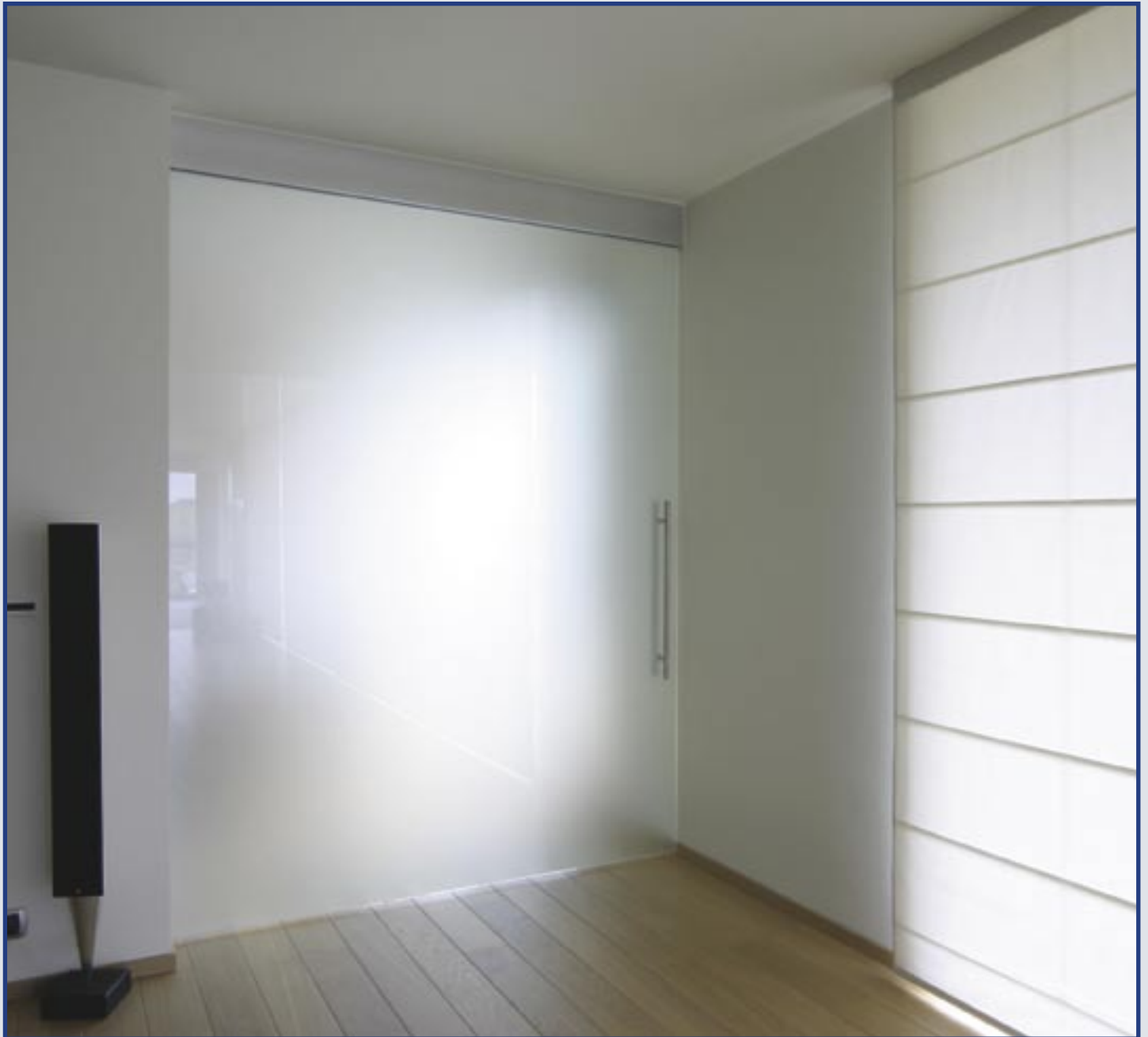

SLIDING DOOR SYSTEMS

SDS 60-100

SLIDING DOOR SYSTEMS

300

pre-drilled rail

300

SDS 60

110

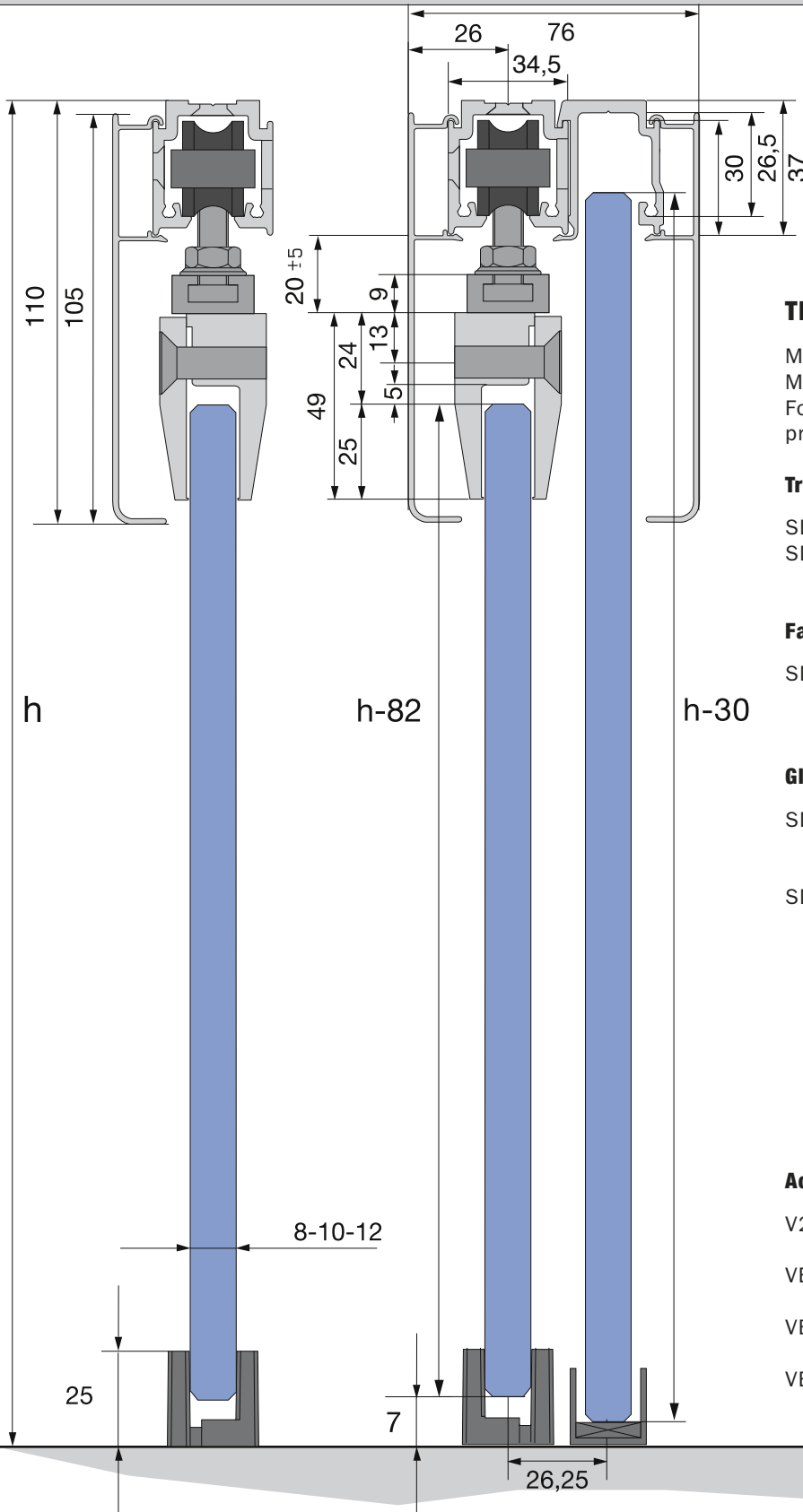

TECHNICAL INFORMATION

Max. door weight 60kg and 100kg
 Max. door height 3000mm
 For glass thickness: 8mm, 10mm, 12mm, no glass preparation required

Track:

SDS010 Pre-drilled track profile
 SDS020 Pre-drilled clip-on profile for fixed panel

Fascia:

SDS105 105 mm high cover available in different aluminum anodized or powder coated finishes

Glass Clamp Kits:

SDS060 Universal Glass Clamp Kit for 8mm, 10mm and 12mm glass with maximum capacity 60kg
 SDS100 Universal Glass Clamp Kit for 8mm, 10mm and 12mm glass with maximum capacity 100kg

All Glass Clamp Kits consist of two hanger assemblies, two glass clamps, an adjustable floor guide, two adjustable retaining stops and gaskets to accept 8mm, 10mm and 12mm tempered glass panels.

Accessories:

V252 Hook lock for sliding door for 8mm, 10mm and 12mm glass
 VB94 Hook lock for sliding door available for glass thickness of 10mm and 12mm
 VB95 Strike patch for VB94 available for glass thickness of 10mm and 12mm
 VB96 Strike plate for hook lock

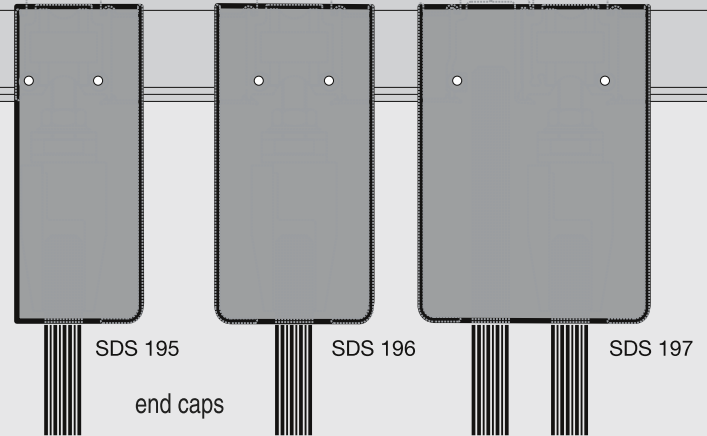
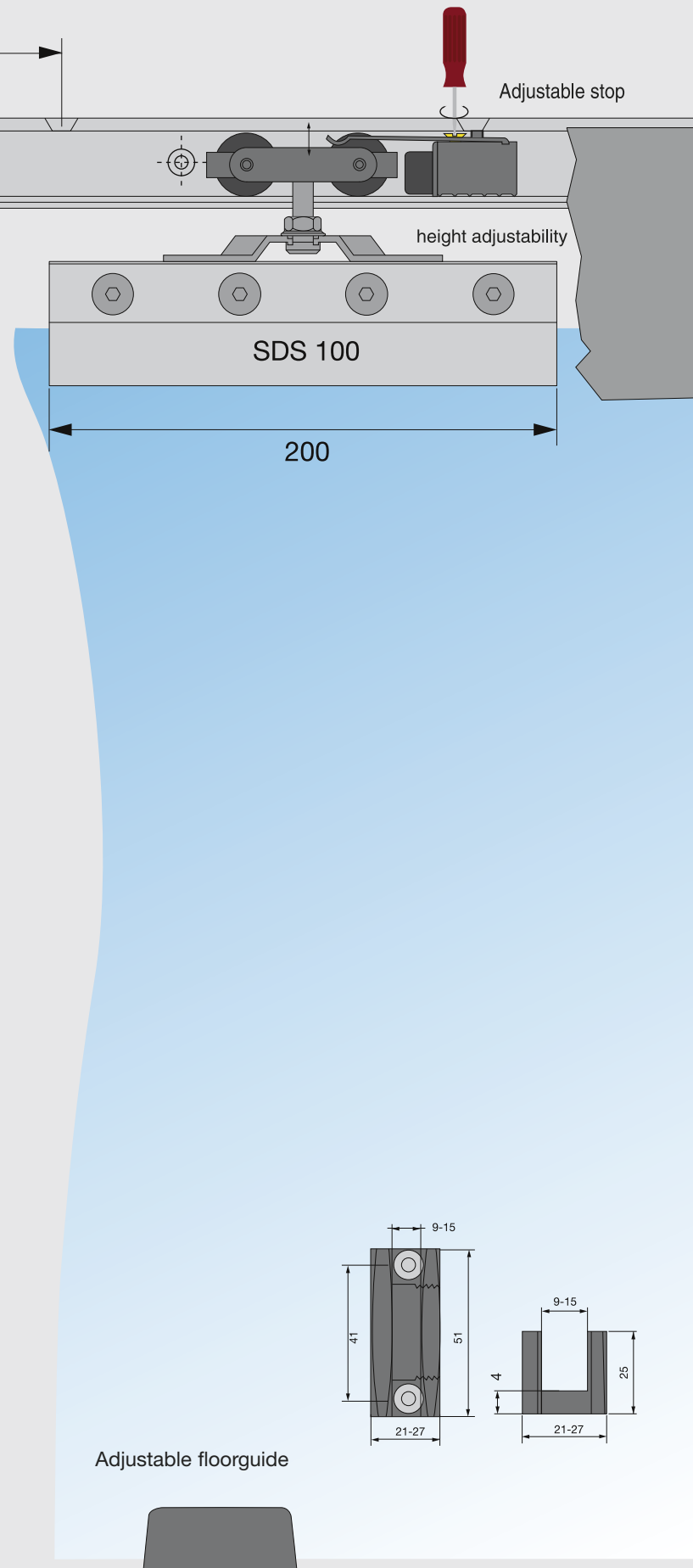

GENERAL DESCRIPTION

The SDS 60 and SDS 100 Sliding Door System offers a solution for light and middle weight applications up to 100kg as interior office doors and smaller glass partitions. It accommodates both sliding door and fixed panels.

The distance between the sliding door and the fixed panel is reduced to a minimum. There is 10mm height adjustability, the track profile is pre-drilled for both wall and ceiling mounting, floor guide is adjustable for different glass thicknesses and the force of stoppers is adjustable as well. There are end caps available for every possible door type.

DOOR TYPES

For tempered glass door panels of 8mm, 10mm and 12mm thick-ness. For fixed glass panels a pre-drilled clip-on profile (SDS020) is available, allowing the sliding door panel to pass alongside the fixed panel.

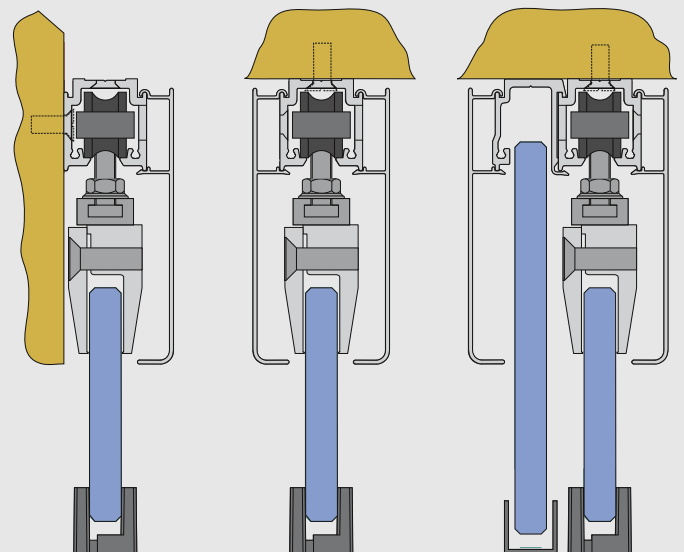

• When using glass clamps in the combination with protective coatings for glass surfaces such as Clear Shield ensure that the glass surfaces to be clamped are not treated with the protective coating.

SDS 60-100

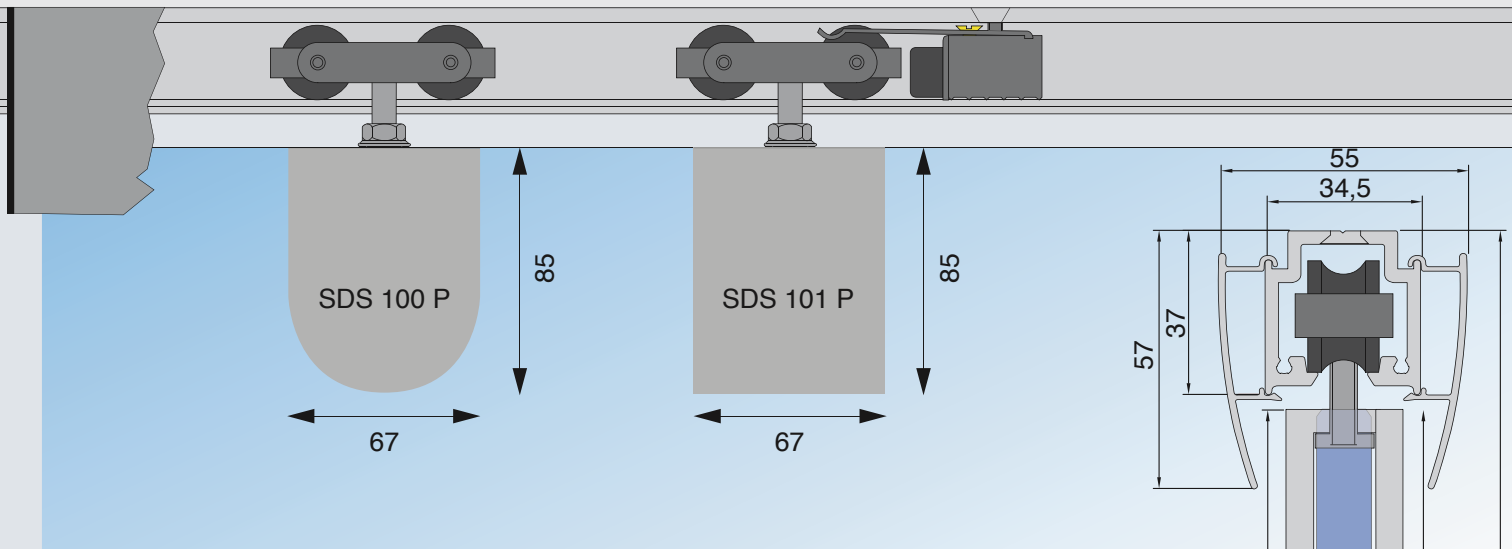

Glass Clamp Kits:

SDS100P Universal Glass Clamp Kit for 8mm,10mm and 12mm glass with maximum capacity 100kg, with round-shaped covers.

SDS101P Universal Glass Clamp Kit for 8mm,10mm and 12mm glass with maximum capacity 100kg, with rectangular shaped covers.

All Glass Clamp Kits consist of two hanger assemblies, two glass clamps, an adjustable floor guide, two adjustable retaining stops and gaskets to accept 8mm,10mm and 12mm tempered glass panels.

Covers available in different aluminum anodized or powder coated finishes

For all commercial and technical information, please contact one of the companies listed below:

■ ■ ■ Glass Hardware Belgium

Puursesteenweg 371
2880 Bornem - Belgium
T.+32 - (0)3 - 899 18 22
F.+32 - (0)3 - 899 14 11
info@glasshardware.be
www.glasshardware.be

■ ■ ■ MAB

Via del Tuscolano 6
40128 Bologna -Italy
T.+39 -051 3540780
F.+39 -051 325108
mab@mab-spa.com
www.mab-spa.com

Glass preparation:

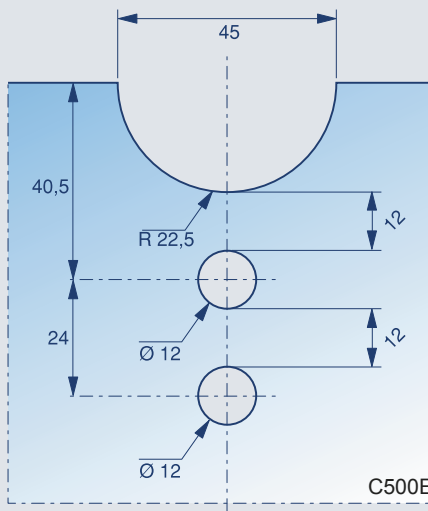

■ ■ ■ Stremler

Route Nationale
80860 Nouvion-en-Ponthieu - France
T.+33 -(0)3 22 23 76 00
F.+33 -(0)3 22 23 28 01
accueil@stremler.fr
www.stremler.fr

■ ■ ■ MAB Glasbeschläge GmbH Deutschland

August-Borsig-Straße 1
DE-03229 Altdöbern
Deutschland
T. +49 -(0)35434 143 40
F. +49 -(0)35434 143 41
mabglasbeschlaege@t-online.de

Stremler Glass Hardware is the specialist in providing the best designed and functional range of glass door hardware solutions.

The ASSA ABLOY group is the world's leading manufacturer and supplier of locking solutions, dedicated to satisfying end-user needs for security, safety and convenience.