

PYROBELITE 12
FIRE RATING:
60 MINUTES INTEGRITY/LOW RADIATION GLASS

DESCRIPTION

Pyrobelite is a laminated glass assembled with clear intumescent interlayers. In the event of fire, the interlayer expands at around 120° C and transforms into a rigid and opaque fire shield, which enables the glazing to meet the integrity criterion of BS 476: Part 22: 1987 and to keep the heat radiation to a very low and safe level.

TECHNICAL DATA

SPECIFICATION & IDENTIFICATION	PYROBELITE 12 EW60 AGC
Glazing Type	Single
Grade	Internal
Nominal Thickness	12,3 mm
Thickness Tolerance	± 1 mm
Weight	27 kg/m ²
Dimension Tolerance	± 2 mm
Light Transmission (EN410)	86 %
U _g Value (EN673)	5.6 W/(m ² .K)
Safety Rating (BS 6206) (EN12600)	Class B 2B2
Sound Reduction - Rw Index (EN12758)	36 dB

APPLICATIONS AND CERTIFICATION ACCORDING TO BS 476:PART 22:1987

APPLICATIONS	MAXIMUM DIMENSIONS (*)	GLASS TYPE (Width x Height)	CERTIFICATION
Timber Doorsets (Certifire & Q-Mark approved)	710 x 1830 mm	Pyrobelite 12	Certifire CF377 Chiltern Chilt/A05178
Timber Screens	914 x 2400 mm 1480 x 1480 mm	Pyrobelite 12	Certifire CF377
Steel Screens	695 x 2040 mm 1424 x 692 mm 1538 x 641 mm	Pyrobelite 12	Certifire CF377

(*) For alternative dimensions within pane area please consult AGC Flat Glass Europe

PYROBELITE 12

(dimensions in mm)

Timber Doorset

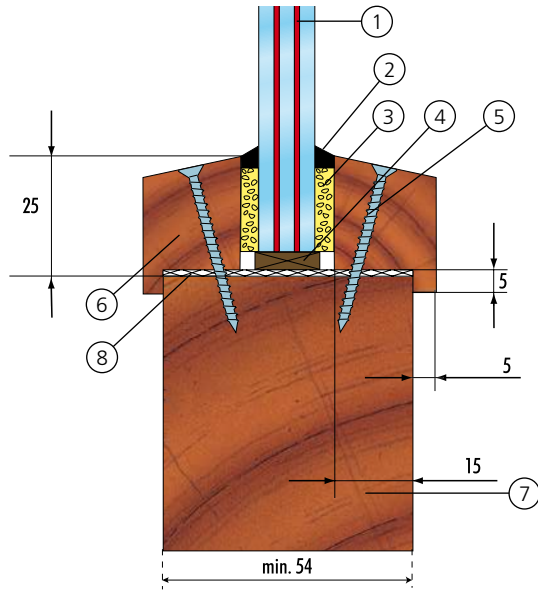

REPORT CHILTERN CHILT/A05178

Timber Screen

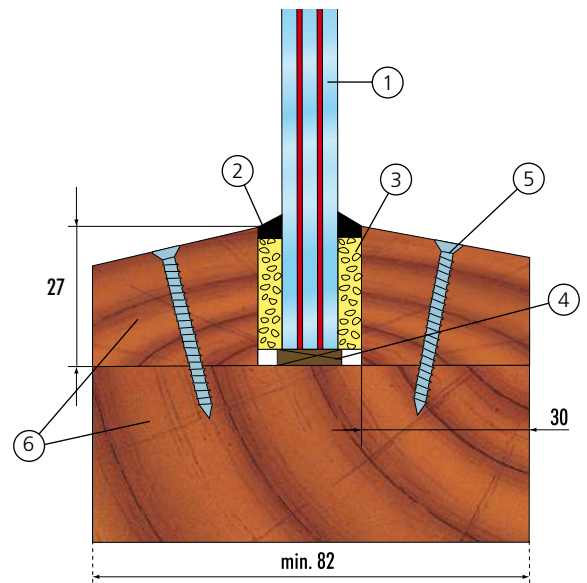

REPORT CERTIFIRE CF377

Steel Screen - Jansen Economy 50

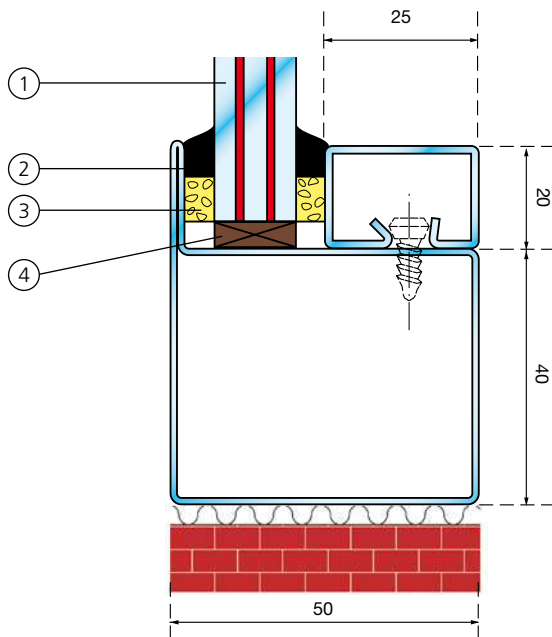

Report Certifire CF377

- | | |
|----------------------------------|--|
| 1 Pyrobelite 12 | 5 Steel screws 60 mm long |
| 2 Neutral silicone | 6 Hardwood |
| 3 Ceramic fibre paper 5 mm thick | 7 Wood or other approved constructions |
| 4 Setting block 4 mm thick | 8 Therm-A-Strip 2 mm thick |

Diagrams for illustration purposes only. For full glazing details please refer to the relevant test report.

www.yourglass.com



Overseas markets : AGC Flat Glass Europe - Seneffe plant - Tel. : +32(0)64 51 05 19 - Fax : +32(0)64 55 80 80 - pyrobel@eu.agc-flatglass.com
 United Kingdom & Ireland : AGC Flat Glass United Kingdom - Tel. : +44(0)1788 535353 - Fax : +44(0)1788 560853 - sales.uk@eu.agc-flatglass.com